

**CC-3
Pile Lifter**

**Model: C25120-02, 12 (115V)
C25120-03, 13 (230V)**

OPERATION

SERVICE

PARTS

CARE

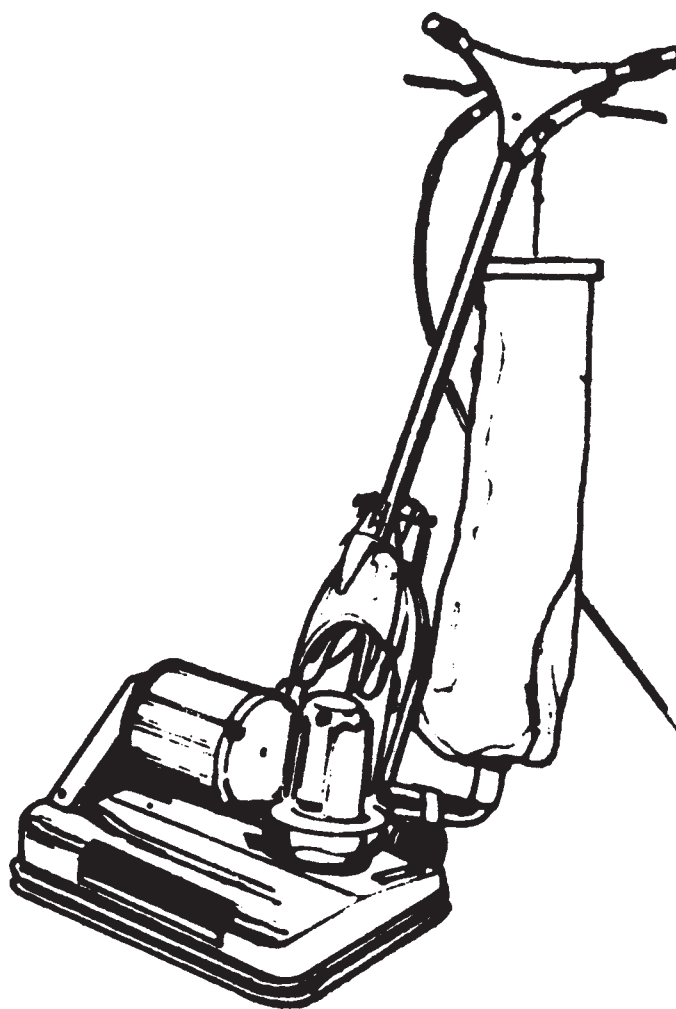

Revised 4/94

Minuteman[®]

FOR COMMERCIAL USE ONLY

IMPORTANT SAFETY INSTRUCTIONS

When using an electrical appliance, basic precautions should always be followed, including the following:

READ ALL INSTRUCTIONS BEFORE USING

WARNING - To reduce the risk of fire, electric shock, or injury:

- Do not leave appliance when plugged in. Unplug from outlet when not in use and before servicing.

WARNING

To reduce the risk of electrical shock - Do not use on wet surfaces. Do not expose to rain. Store indoors.

- Do not allow to be used as a toy. Close attention is necessary when used by or near children.
- Use only as described in this manual. Use only manufacturer's recommended attachments.
- Do not use with damaged cord or plug. If appliance is not working as it should, has been dropped, damaged, left outdoors, or dropped into water, return it to a service center.
- Do not pull or carry by cord, use cord as a handle, close a door on cord, or pull cord around sharp edges or corners. Do not run appliance over cord. Keep cord away from heated surfaces.
- Do not unplug by pulling on cord. To unplug, grasp the plug, not the cord.
- Do not handle plug or appliance with wet hands.
- Do not put any object into openings. Do not use with any opening blocked; keep free of dust, lint, hair, and anything that may reduce air flow.
- Keep hair, loose clothing, fingers, and all parts of body away from openings and moving parts.
- Do not pick up anything that is burning or smoking, such as cigarettes, matches, or hot ashes.
- Do not use without dustbag and/or filters in place.
- Turn off all controls before unplugging.
- Use extra care when cleaning on stairs.
- Do not use to pick up flammable or combustible liquids such as gasoline or use in areas where they may be present.
- Connect to a properly grounded outlet only. See grounding instructions.

SAVE THESE INSTRUCTIONS

OPERATING INSTRUCTIONS

Model C25120-02, 12

INSPECTION

Carefully unpack and inspect your machine for shipping damage. Each unit is tested and thoroughly inspected before shipment, and any damage is the responsibility of the delivery carrier who should be notified immediately.

ELECTRICAL

This machine is designed to operate on a standard 15 amp., 115 volt, 50 hz, AC circuit. Voltages below 105 volts AC or above 125 volts AC could cause serious damage to the motor.

WARNING

Electric motors can cause explosions when operated near explosive materials or vapors. Do not operate this machine near flammable materials such as solvents, thinners, fuels, grain dust, etc.

GROUNDING INSTRUCTIONS

This appliance must be grounded. If it should malfunction or breakdown, grounding provides a path of least resistance for electric current to reduce the risk of electric shock. This appliance is equipped with a cord having an equipment-grounding conductor and grounding plug. The plug must be plugged into an appropriate outlet that is properly installed and grounded in accordance with all local codes and ordinances.

DANGER - Improper connection of the equipment-grounding conductor can result in a risk of electric shock. Check with a qualified electrician or service person if you are in doubt as to whether the outlet is properly grounded. Do not modify the plug provided with the appliance -- if it will not fit the outlet, have a proper outlet installed by a qualified electrician.

This appliance is for use on a nominal 120-volt circuit and has a grounding plug that looks like the plug illustrated in sketch A below. Make sure that the appliance is connected to an outlet having the same configuration as the plug. No adapter should be used with this appliance.

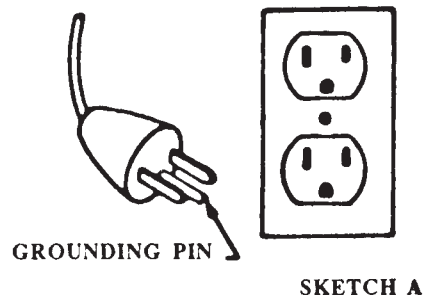

OPERATING INSTRUCTIONS

Model C25120-03, 13

INSPECTION

Carefully unpack and inspect your machine for shipping damage. Each unit is tested and thoroughly inspected before shipment, and any damage is the responsibility of the delivery carrier who should be notified immediately.

ELECTRICAL

This machine is designed to operate on a standard 16 amp. type L fused 230 volt, 50 hz, AC circuit. Voltages below 200 volts AC or above 250 volts AC could cause serious damage to the motor. I.E.C. Class 1.

WARNING

Electric motors can cause explosions when operated near explosive materials or vapors. Do not operate this machine near flammable materials such as solvents, thinners, fuels, grain dust, etc.

GROUNDING INSTRUCTIONS

This appliance must be grounded. If it should malfunction or breakdown, grounding provides a path of least resistance for electric current to reduce the risk of electric shock. This appliance is equipped with a cord having an equipment-grounding conductor and grounding plug. The plug must be plugged into an appropriate outlet that is properly installed and grounded in accordance with all local codes and ordinances.

DANGER - Improper connection of the equipment-grounding conductor can result in a risk of electric shock. Check with a qualified electrician or service person if you are in doubt as to whether the outlet is properly grounded. Do not modify the plug provided with the appliance -- if it will not fit the outlet, have a proper outlet installed by a qualified electrician.

OPERATION 115/230V Models

Conditioning Carpet: For dry conditioning, vacuum entire room or desired area. Press the starting lever switch and walk forward for the full length of the room or area. The rotation of the cylindrical brush will propel the machine forward. For effective use, hold back slightly to allow the pile lifting brush to dig out the imbedded soil. Do not raise handle to put extra weight on brush, as this will cause the motor to overheat and could cause a burn-out. Added pressure on the brush does not increase cleaning efficiency. The extra pressure slows the brush, reducing dirt pick-up.

Retrace by pulling the machine back over the same area. This combs the pile and removes grit. (Slight downward pressure should be exerted on the handle while pushing backwards. This relieves some of the pressure on the brush and prevents an overload on the motor and a loss of cleaner efficiency due to reduced brush speed.)

Use hand brush in corners and other inaccessible areas.

MAINTENANCE

Brush Housing: The underside of the brush housing has a compartment to catch heavy dirt and objects that are not carried into the dust bag. To empty this compartment, tip the machine back so that the front of the housing is off the floor. Release spring holder on cover plate at rear of machine and open. This allows all debris caught in the compartment to drop out. To close, push cover plate bck inspection firmly and replace spring holder.

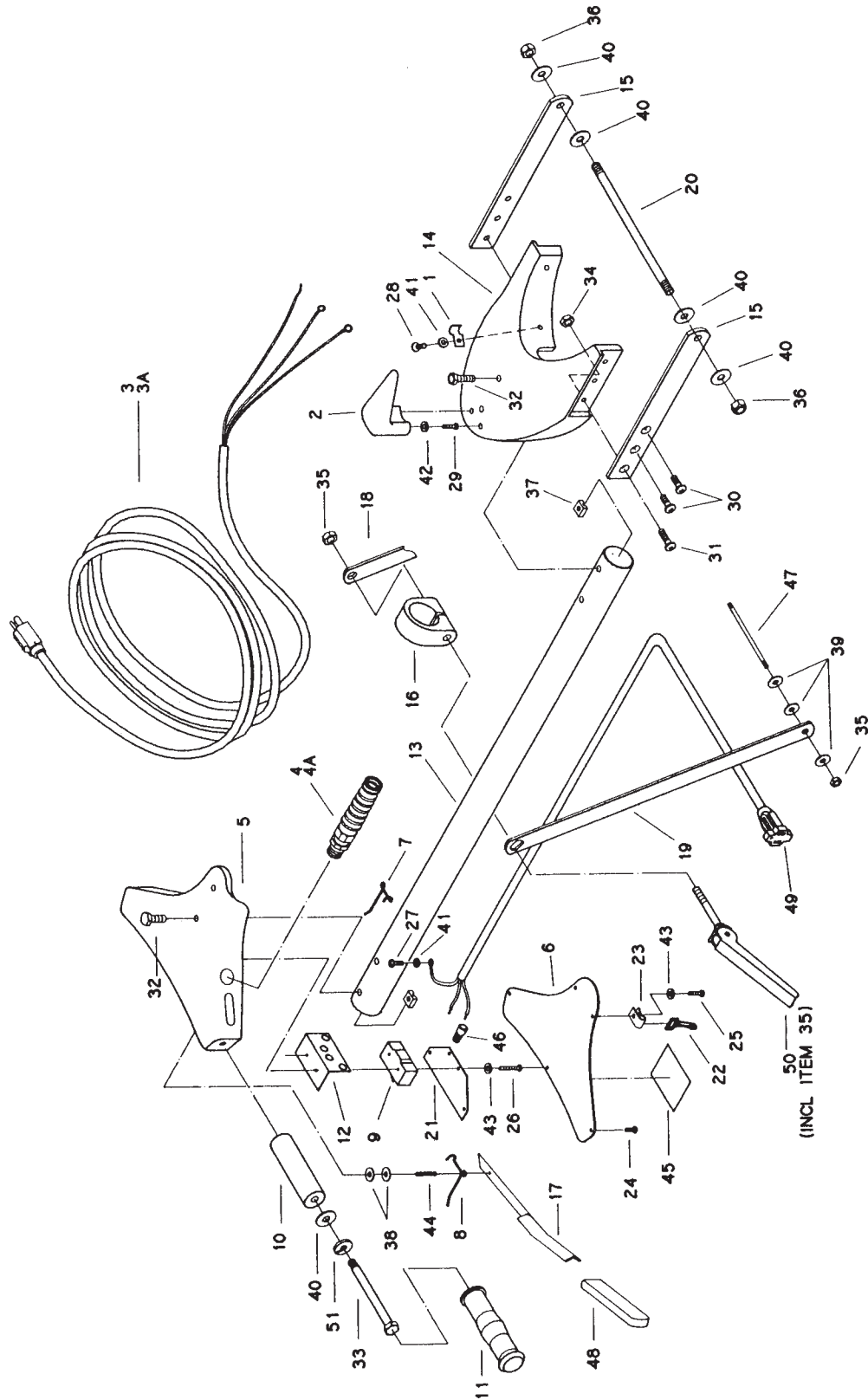

Parts List

Item	Part No.	Qty.	Description	Item	Part No.	Qty.	Description
1	130010	1	Clamp, Cord	26	710307	2	SCR-MC 6-32 x 1.00
2	130017POL	1	Hook, Cord	27	710352	1	SCR-MC 10-32 x .25
3	150002	1	Orange Cord Set 14-3 50'	28	710353	1	SCR-MC 10-32 x .37
3A	829880	1	Power Cord 14/3 International	29	710380	2	SCR-MC 1/4-20 x .75
4	150003	1	Relief, Strain	30	710477	4	SCR-MC 1/4-20 x .50
4A	150004	1	Relief, Strain	31	710480	2	SCR-MC 1/4-20 x .87
5	160002POL	1	Housing, Handle	32	711229	4	BLT-HH 5/16-18 x .87
6	160004	1	Plate, Switch Case	33	711245	2	BLT-HH 3/8-16 x 4.50
7	160007	1	Spring, Lever Right	34	711316	2	Nut-Hex 1/4-20
8	160008	1	Spring, Lever Left	35	711374	3	Nut-Nyloc 5/16-18
9	160012	1	Switch, Handle	36	711375	2	Nut-Nyloc 3/8-16
10	160014	2	Core, Handle	37	711398	4	Nut-Sq. Speed 5/16-18
11	160015	2	Grip, Handle Black	38	711503	2	WSR-Flat #10
12	160021	1	Insulator	39	711506	4	WSR-Flat 5/16
13	160022PLT	1	Handle Tube	40	711515	6	WSR-Flat .44 x .87 x .07
14	160023POL	1	Bracket, Lower Handle	41	711543	2	WSR-Helical #10
15	160025PLT	2	Bracket, Arm	42	711544	2	WSR-Helical 1/4
16	160026POL	1	Clamp 1 1/2	43	711551	3	WSR-Internal Lock #6
17	160028	2	Lever, Switch	44	711635	2	Rollpin .156 x 1.375
18	160029PLT	1	Brace, Handle	45	715062	1	General Warning Decal
19	160030	1	Handle Brace	46	740005	2	Cap, Wire
20	160033	1	Pin, Hinge	47	250105	1	Bolt, Handle Yoke
21	160095	1	Plate, Support	48	761197	2	Grip, Black
22	250037	1	Clip, Bag	49	762156	1	Cord, Handle
23	250038	1	Retainer, Bag Clip	50	807674	1	Kick Lever Kit
24	710202	5	SCR-MC 6-32 x .25	51	711546	2	WSR-Helical 3/8
25	710204	1	SCR-MC 6-32 x .50				

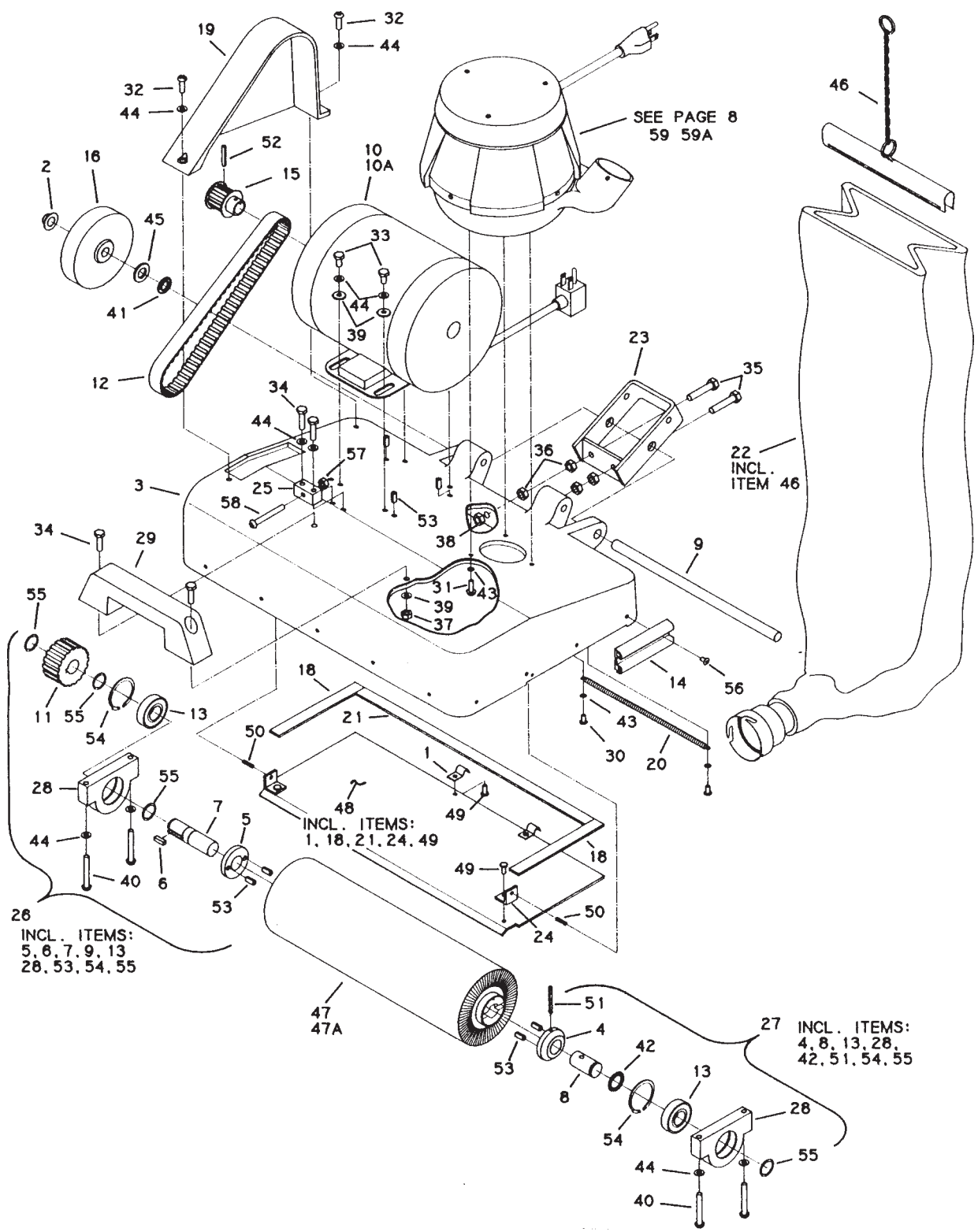

26
INCL. ITEMS:
5, 6, 7, 9, 13
28, 53, 54, 55

INCL. ITEMS:
1, 18, 21, 24, 49

27 INCL. ITEMS:
4, 8, 13, 28,
42, 51, 54, 55

SEE PAGE 8
59 59A

22 INCL.
ITEM 46

Parts List

Item	Part No.	Qty.	Description
1	130010	2	Clamp, Cord
2	130032	2	Cap, Retainer
3	250001PTD	1	Housing CC3
4	250003	1	Plate, Idler Drive
5	250004	1	Plate, Drive
6	250005	1	Key .187 Square
7	250006	1	Shaft, Drive
8	250007	1	Shaft, Idler
9	250009	1	Axle
10	250010	1	Motor, 1/2 HP 115V 60 HZ
10A	250022	1	Motor, 1/2 HP 208/240V 50HZ
11	250013	1	Pulley .75 Bore
12	250014	1	Belt
13	250016	2	Bearing
14	250020	1	Black Bumper
15	250023	1	Pulley Motor
16	250024	2	Wheel
18	250030	2	Seal, Rubber
19	250032PTD	1	Belt Guard
20	250040	1	Spring, Extension
21	250041	1	Seal, Rubber
22	250072	1	Bag, Shakeout CC3
23	250092	1	Bracket Brace Assembly
24	250093	2	Bracket
25	250107	1	Block, Adjusting
26	250137	1	Bearing Assembly Driver
27	250138	1	Pillow Block Assembly Idle
28	250139MCH	2	Pillow Block
29	460001	1	Handle
30	710353	2	SCR-MC 10-32 x .37
31	710357	3	SCR-MC 10-32 x .75
32	710380	2	SCR-MC 1/4-20 x .75
33	711204	4	BLT-HH 1/4-20 x .75
34	711207	4	BLT-HH 1/4-20 x 1.00
35	711232	2	BLT-HH 5/16-18 x 1.50
36	711319	4	Nut-Hex 5/16-18
37	711373	2	Nut-Nyloc 1/4-20
38	711374	2	Nut-Nyloc 5/16-18
39	711505	4	WSR-Flat 1/4
40	710387	4	SCR-MC 1/4-20 x 1.75
41	711524	2	WSR-Wave .52 x .87 x .01
42	711525	1	WSR-Wave .65 x .86 x .01
43	711543	5	WSR-Helical #10
44	711544	12	WSR-Helical 1/4
45	711579	2	WSR-Flat .56 x 1.00
46	750669	1	Bag Clamp Assembly
47	750627	1	Brush Assembly Union Mix Comp.
47A	750625	1	Brush Assembly Nylon Comp.
48	750027	1	Clean-out Door Assembly
49	711916	4	Rivet, Tube
50	711632	2	Rollpin .156 x .62
51	711636	1	Rollpin .156 x 1.50
52	711642	1	Rollpin .187 x 1.00
53	711656	8	Rollpin .25 x .50
54	711702	2	Retaining Ring - Int. 1.62
55	711715	3	Retaining Ring - Int. .75
56	711903	17	Rivet - Pop
57	711316	1	1/4-20 Hex Nut
58	711212	1	1/4-20 x 1.50 HH Bolt
59	200050	1	115V Blower Assembly
59A	200060	1	240V Blower Assembly

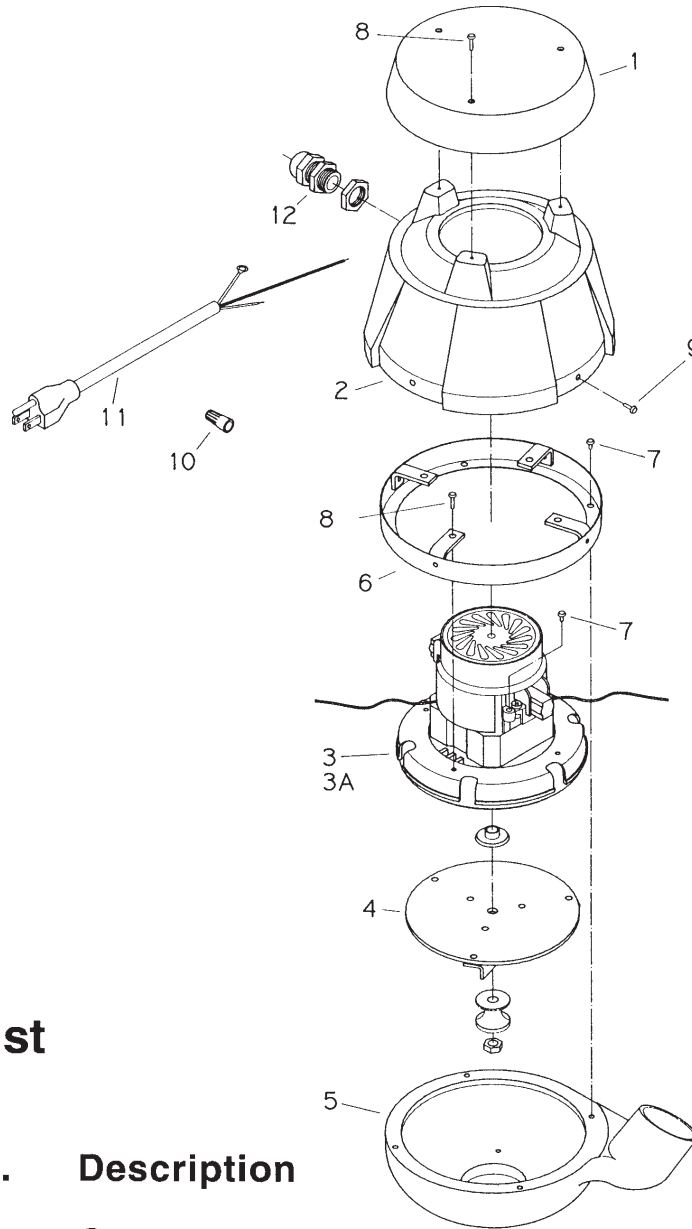

Parts List

Item	Part No.	Qty.	Description
1	200051	1	Cover
2	200052	1	Vac Motor Housing
3	200055	1	Blower Motor 115V
3A	200061	1	Blower Motor 230V
4	200056	1	Blower Fan
5	200059	1	Lower Housing
6	200062	1	Motor Mounting Bracket
7	711124	5	SCR-ST-B #10 x .37
8	711168	4	SCR-ST-B #10 x .5
9	711160	8	SCR HI-LO #10
10	740006	2	Wire Cap
11	762146	1	Cord
12	830696	1	Strain Relief

LIMITED WARRANTY

Minuteman International, Inc. warrants to the original purchaser/user that this product is free from defects in workmanship and materials under normal use and service for a period of three years from date of purchase. In addition, Minuteman International, Inc. will, at its option, honor labor warranty claims for the first 12 months from date of sale, provided such claims are submitted through and approved by factory authorized repair stations. Minuteman International, Inc. will, at its option, repair or replace without charge, except for transportation costs, parts that fail under normal use and service when operated and maintained in accordance with the applicable operation and instruction manuals.

This warranty does not apply to normal wear, or to items whose life is dependent on their use and care, such as belts, cords, switches, hoses, rubber parts, electrical motor components or adjustments. Parts not manufactured by Minuteman International, Inc. such as engines, batteries, battery chargers, hydraulic pumps, and tires are covered by and subject to the warranties and/or guarantees of their manufacturers. Please contact Minuteman International, Inc. for procedures in warranty claims against these manufacturers.

Special warning to purchaser — Use of replacement filters and/or prefilters not manufactured by Minuteman International, Inc. or its designated licensees, will void all warranties expressed or implied.

A potential health hazard exists without exact original equipment replacement.

All warranted items become the sole property of Minuteman International, Inc. or its original manufacturer, whichever the case may be.

Minuteman International, Inc. disclaims any implied warranty, including the warranty of merchantability and the warranty of fitness for a particular purpose. Minuteman International, Inc. assumes no responsibility for any special, incidental or consequential damages.

This limited warranty is applicable only in the U.S.A. and Canada, and is extended only to the original user/purchaser of this product. Customers outside the U.S.A. and Canada should contact their local distributor for export warranty policies. Minuteman International, Inc. is not responsible for costs or repairs performed by persons other than those specifically authorized by Minuteman International, Inc. This warranty does not apply to damage from transportation, alterations by unauthorized persons, misuse or abuse of the equipment, use of non-compatible chemicals, or damage to property, or loss of income due to malfunctions of the product.

If a difficulty develops with this machine, you should contact the dealer from whom it was purchased.

This warranty gives you specific legal rights, and you may have other rights which vary from state to state. Some states do not allow the exclusion or limitation of special, incidental or consequential damages, or limitations on how long an implied warranty lasts, so the above exclusions and limitations may not apply to you.

Minuteman[®]

World Headquarters
Minuteman International, Inc.
111 South Rohlwing Road
Addison, Illinois 60101

Minuteman Canada, Inc.
2210 Drew Road
Mississauga, Ontario
L5S 1B1

(630) 627-6900
FAX (630) 627-1130

(905) 673-3222
FAX (905) 673-5161

985102
Printed in U.S.A.